

Power Quality Improvement Using Interline Unified Power Quality Conditioner

Srikanth Punna,

¹Assistant Professor, Department of Electrical and Electronics Engineering,
Nagole Institute of Science and Technology, Ranga Reddy, Telangana India.

ABSTRACT: - Power quality has become an important factor in power systems, for consumer and household appliances with proliferation of various electric/ electronic equipment and computer systems. The main causes of a poor power quality are harmonic currents, poor power factor, supply voltage variations, etc. In recent years the demand for the quality of electric power has been increased rapidly. Power quality problems have received a great attention nowadays because of their impacts on both utilities and customers. Voltage sag, swell, momentary interruption, under voltages, over voltages, noise and harmonics are the most common power quality disturbances. This paper proposes a new connection for a unified power quality conditioner (UPQC) to improve the power quality of two feeders in a distribution system. This paper illustrates how UPQC can improve the power quality by mitigating all these PQ disturbances. The proposed configuration of the UPQC is developed and verified for various Power Quality disturbances by simulating the model using PSCAD/EMTDC. The disturbances considered here are according to IEC Electromagnetic Compatibility Standards.

I. INTRODUCTION

The quality of power supply has become a major concern of electricity users. If the quality of power supply is not good then it may result in malfunctions, instabilities, short life time, and so on. Poor power quality is mainly due to adjustable speed drives. The power quality

Unified Power Quality Conditioner (UPQC) consists of two IGBT based Voltage source converters (VSC), one shunt and one series cascaded by a common DC bus. The shunt converter is connected in parallel to the load. It provides VAR support to the load and supply harmonic currents. Whenever the supply voltage undergoes sag then series converter injects suitable voltage with supply. Thus UPQC improves

the power quality by preventing load current harmonics and by correcting the input power factor.

Voltage-Source Converter based Custom power devices are increasingly being used in custom power applications for improving the power quality (PQ) of power distribution systems. Devices such as distribution static compensator (DSTATCOM) and dynamic voltage restorer (DVR) are extensively being used in power quality improvement. A DSTATCOM can compensate for distortion and unbalance in a load such that a balanced sinusoidal current flows through the feeder. It can also regulate the voltage of a distribution bus. A DVR can compensate for voltage sag/swell and distortion in the supply side voltage such that the voltage across a sensitive/critical load terminal is perfectly regulated.

This paper presents the new connection for UPQC. i.e. INTERLINE UNIFIED POWER QUALITY CONDITIONER (IUPQC) which is the most sophisticated mitigating device for the power quality disturbances. It was firstly introduced to mitigate the current harmonics and voltage disturbances. The main aim of the IUPQC is to hold the voltages V_{t1} and V_{t2} constant against voltage sag/swell/any power disturbances in either of the feeders. Many contributions were introduced to modify the configurations and the control algorithms to enhance its performance.

CONTROL SCHEME

A. Sinusoidal PWM-Based Control Scheme

In order to mitigate the simulated voltage sags in the test system of each mitigation technique, also to mitigate voltage sags in practical application, a sinusoidal PWM-based control scheme is implemented, with reference to IUPQC.

The aim of the control scheme is to maintain a constant voltage magnitude at the point where

sensitive load is connected, under the system disturbance. The control system only measures the rms voltage at load point, in example, no reactive power measurements is required.

The VSC switching strategy is based on a sinusoidal PWM technique which offers simplicity and good response. Since custom power is a relatively low-power application, PWM methods offer a more flexible option than the fundamental frequency switching (FFS) methods favored in FACTS applications. Besides, high switching frequencies can be used to improve the efficiency of the converter, without incurring significant switching losses. Fig.1 shows the IUPQC controller scheme implemented in PSCAD/EMTDC

The IUPQC control system exerts voltage angle control as follows:

An error signal is obtained by comparing the reference voltage with the rms voltage measured at the load point. The PI controller processes the error signal and generates the required angle δ to drive the error to zero, in example, the load rms voltage is brought back to the reference voltage. In the PWM generators, the sinusoidal signal, control, is phase modulated by means of the angle δ or delta as nominated in the Fig.1. The modulated signal, control is compared against a triangular signal (carrier) in order to generate the switching signals of the VSC valves.

The main parameters of the sinusoidal PWM scheme are the amplitude modulation index, ma , of signal control, and the frequency modulation index, mf , of the triangular signal. The vcontrol in the Fig.1 are nominated as CtrlA, CtrlB and CtrlC.

The amplitude index ma is kept fixed at 1 p.u, in order to obtain the highest fundamental voltage component at the controller output. The switching frequency if is set at 450 Hz, $mf = 9$. It should be noted that, an assumption of balanced network and operating conditions are made.

The modulating angle δ or delta is applied to the PWM generators in phase A, whereas the angles for phase B and C are shifted by 240° or -120° and 120° respectively. It can be seen in Fig.1 that the control implementation is kept very simple by using only voltage measurements as feedback variable in the control scheme. The speed of response and robustness of the control scheme are clearly shown in the test results.

The PWM control scheme shown in Fig. 1 is implemented in PSCAD/EMTDC to carry out the IUPQC test simulations. The gain of the PI controller used in this scheme is 700.

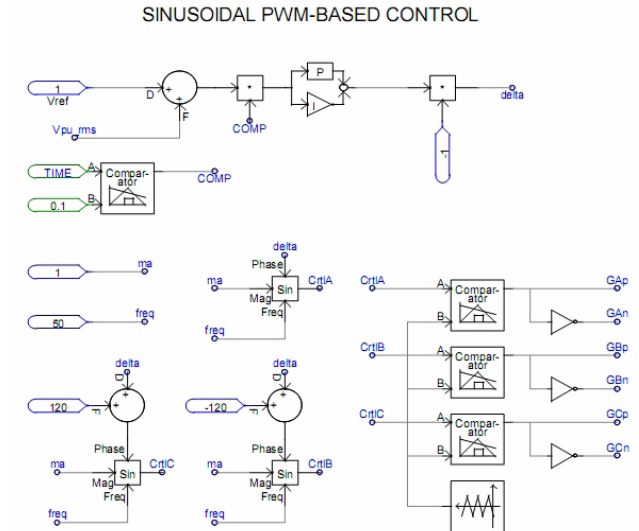

Fig.1. PWM based control scheme

With a view to have a self regulated dc bus, the voltage across the capacitor is sensed at regular intervals and controlled by employing a suitable closed loop control. The DC link voltage, V_{dc} is sensed at a regular interval and is compared with its reference counterpart V_{dc}^* . The error signal is processed in a PI controller. A limit is put on the output of controller this ensures that the source supplies active power of the load and dc bus of the UPQC. Later part of active power supplied by source is used to provide a self supported DC link of the UPQC. Thus, the DC bus voltage of the UPQC is maintained to have a proper current control. Subtraction of load currents from the reference supply currents results in three phase reference currents for the shunt inverter.

These reference currents are compared with actual shunt compensating currents and the error signals are then converted into (or processed to give) switching pulses using PWM technique which are further used to drive shunt inverter. In response to the PWM gating signals the shunt inverter supplies harmonic currents required by load. In addition to this it also supplies the reactive power demand of the load.

In effect, the shunt bi-directional converter that is connected through an inductor in parallel with the load terminals accomplishes three functions simultaneously. It injects reactive current to compensate current harmonics of the load. It provides

reactive power for the load and thereby improve power factor of the system. It also draws the fundamental current to compensate the power loss of the system and make the voltage of DC capacitor constant.

II. INTERLINE UNIFIED POWER QUALITY CONDITIONER (IUPQC)

The IUPQC shown in Fig.2 consists of two VSCs (VSC-1 and VSC-2) that are connected back to back through a common energy storage dc capacitor. Let us assume that the VSC-1 is connected in shunt to Feeder-1 while the VSC-2 is connected in series with Feeder-2. Each of the two VSCs is realized by three H-bridge inverters. In its structure, each switch represents a power semiconductor device (e.g., IGBT) and an anti-parallel diode. All the inverters are supplied from a common single dc capacitor C_{dc} and each inverter has a transformer connected at its output.

The complete structure of a three-phase IUPQC with two such VSCs is shown in Fig. 2. The secondary (distribution) sides of the shunt-connected transformers (VSC-1) are connected in star with the neutral point being connected to the load neutral. The secondary winding of the series-connected transformers (VSC-2) are directly connected in series with the bus B-2 and load L-2. The ac filter capacitors C_f and C_k are also connected in each phase to prevent the flow of the harmonic currents generated due to switching. The six inverters of the IUPQC are controlled independently. The switching action is obtained using output feedback control. An IUPQC connected to a distribution system is shown in Fig. 2. In this figure, the feeder impedances are denoted by the pairs (R_{s1}, L_{s1}) and (R_{s2}, L_{s2}) . It can be seen that the two feeders supply the loads L-1 and L-2. The load L-1 is assumed to have two separate components—an unbalanced part (L-11) and a non-linear part (L-12). The currents drawn by these two loads are denoted by i_{l1} and i_{l2} , respectively. We further assume that the load L-2 is a sensitive load that requires uninterrupted and regulated voltage.

The shunt VSC (VSC-1) is connected to bus B-1 at the end of Feeder-1, while the series VSC (VSC-2) is connected at bus B-2 at the end of Feeder-2. The voltages of buses B-1 and B-2 and across the sensitive load terminal are denoted by V_{t1} , V_{t2} , and V_{l2} , respectively.

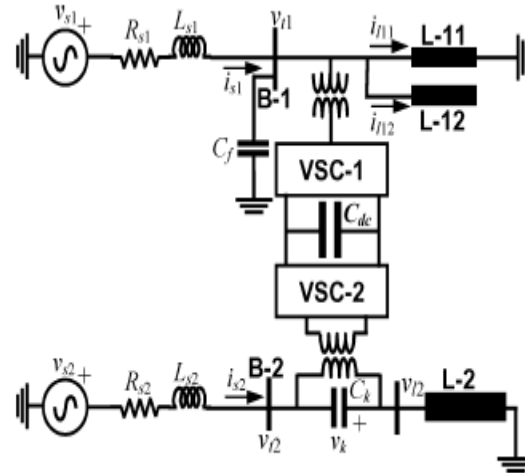

Fig.2. Typical IUPQC connected in a distribution system

The aim of the IUPQC is two-fold:

To protect the sensitive load L-2 from the disturbances occurring in the system by regulating the voltage V_{l2} ;

- To regulate the bus B-1 voltage V_{t1} against sag/swell and or disturbances in the system.
- In order to attain these aims, the shunt VSC-1 is operated as a voltage controller while the series VSC-2 regulates the voltage across the sensitive load. The length of Feeder-1 is arbitrarily chosen to be twice that of Feeder-2.

The system with the below mentioned parameters is implemented using PSCAD/ EMTDC and is analyzed for various PQ disturbances. One of the VSCs is connected in series with a distribution feeder, while the other one is connected in shunt with the same feeder. The dc links of both VSCs are supplied through a common dc capacitor.

The shunt VSC (VSC-1) holds the voltage of bus B-1 constant. This is accomplished by making VSC-1 to track to a reference voltage across the filter capacitor C_f . It is assumed that the dc capacitor is initially charged and both the feeders along with the IUPQC are connected at time zero. Once the three-phase B-1 voltages become balanced, the currents drawn by Feeder-1 also become balanced. The load L-2 bus voltages are also perfectly sinusoidal with the desired peak as the converter VSC-2 injects the required voltages in the system. The bus B-2 voltages will have a much smaller magnitude.

A 3-phase supply voltage of 11kv line to line, 50Hz with sag of 81% at source end, non-linear and unbalanced load at load end is considered. Non-linear load (Diode Rectifier feeding an RL load) injects current harmonics into the system. IUPQC is able to reduce the harmonics from entering into the system using shunt control. IUPQC with its series voltage control calculates the required voltage to be injected in series with the line to compensate the voltage sag in the insertion transformer produces the series injected (compensated) voltage by drawing the required power from the DC link. IUPQC with shunt PI controller estimates the required current to be injected in shunt with the line to compensate the disturbances.

III. POWER QUALITY IMPROVEMENT USING IUPQC

There are three ways to solve the problems of power quality and provide quality power customized to meet user's requirement:

- System improvement
- Use mitigation equipment based on power electronics
- Improvement of equipment immunity

Of these, the best way to handle power quality problems is to mitigate the effects of distorted voltage or current at the point of common coupling. This would ensure that the harmonics are restricted from entering the distribution system and contaminating the system power as a whole. Thereby, the other loads connected to the system are provided with clean power. This paper illustrates how various power quality disturbances are mitigated using equipment called IUPQC.

Fig.3 Simulation results – Comparison of Waveforms for a voltage sag of 81% with and without UPQC

1) MITIGATION OF VOLTAGE SAG

A 3-phase supply voltage (11kv, 50Hz) with impulsive sag of 0.5 p.u magnitude and the duration about 0.5 to 30 cycles is taken. With the system operating in the steady state, 15 cycle impulsive voltage sag of 0.5 p.u magnitude is occurring at 0.3msec for which the peak of the supply voltage reduces from its nominal value of 10kv to 5kv. The simulation results are shown in Fig.4. The Total Harmonic Distortion (THD) at load side is found to be 0.95%. The source voltage THD is effectively found to be 0.045%.

In order to supply the balanced power required to the load, the DC capacitor voltage drops as soon as the sag occurs. As the sag is removed the capacitor voltage returns to the steady state. The voltage injected by UPQC in kV is shown in Fig. 4(d). Active and reactive powers both on source and load sides are shown in Fig. 4 (e) and Fig. 4(f).

2) MITIGATION OF VOLTAGE SWELL

A 3-phase supply voltage (11kv, 50Hz) with momentaryswell of 0.26 pu magnitude and the duration about 0.5 to 30 cycles is taken. With the system operating in the steady state, a 21 cycle momentary voltage swell of 0.26 p.u magnitude is occurring at 0.3 msec for which the peak of the supply voltage raises from its nominal value of 10kv to 12.6kV. In order to supply the balanced power required to the load, the DC capacitor voltage raises as soon as the swell occurs. As the swell is removed the capacitor voltage returns to the steady state. The Total Harmonic Distortion (THD) at load side is found to be 1.71%. The source voltage THD is effectively found to be 0.045%.

IV. MATLAB CASE STUDY AND SIMULATION RESULTS

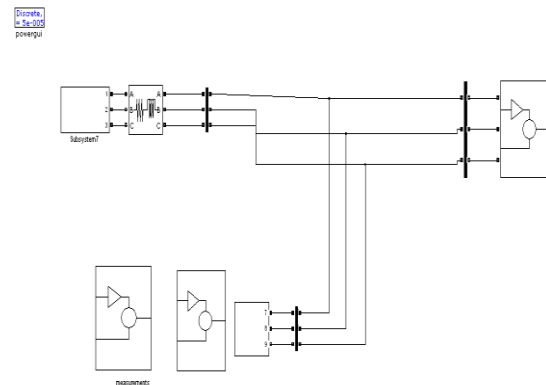

Without upqc

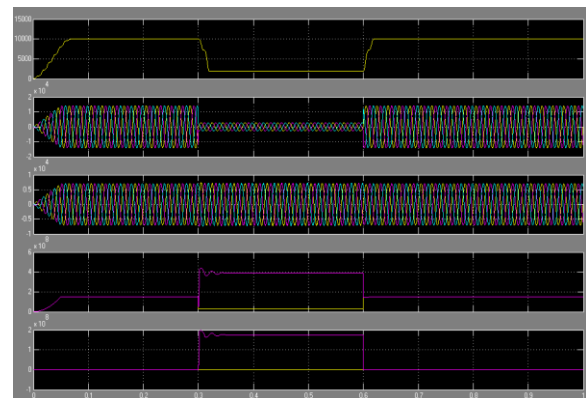

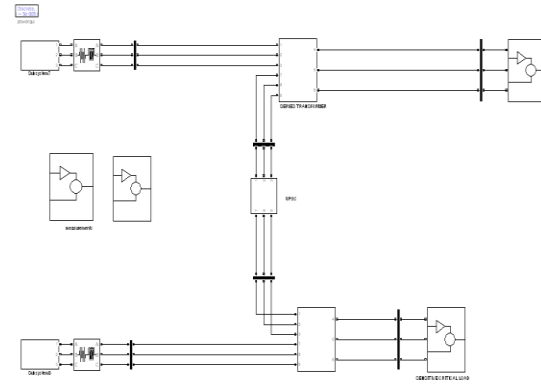
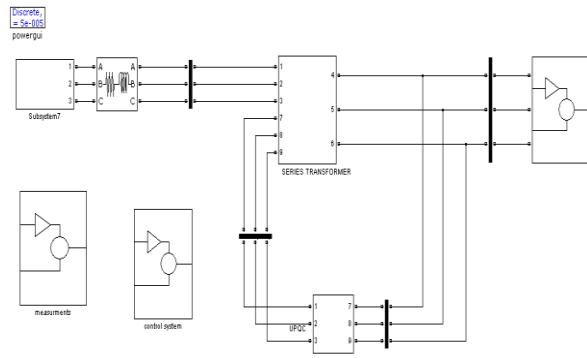

SIMULATION model

With upqc

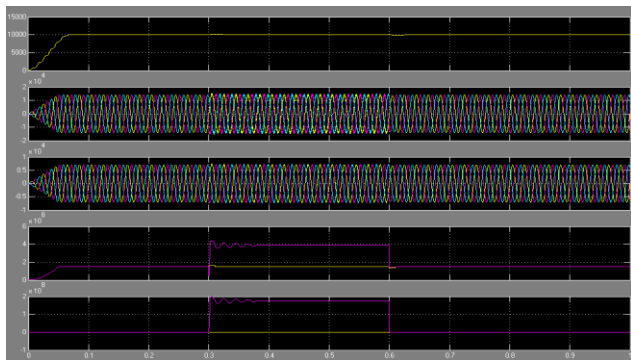

Fig.3 Simulation results – Comparison of Waveforms for a voltage sag of 81% with and without UPQC

- (a) rms load voltage (pu)
- (b) Instantaneous load voltages (kV)
- (c) Instantaneous load currents (kA)
- (d) Load and source active powers (MW)
- (e) Load and source reactive power (MVAR)

MITIGATION OF VOLTAGE SAG

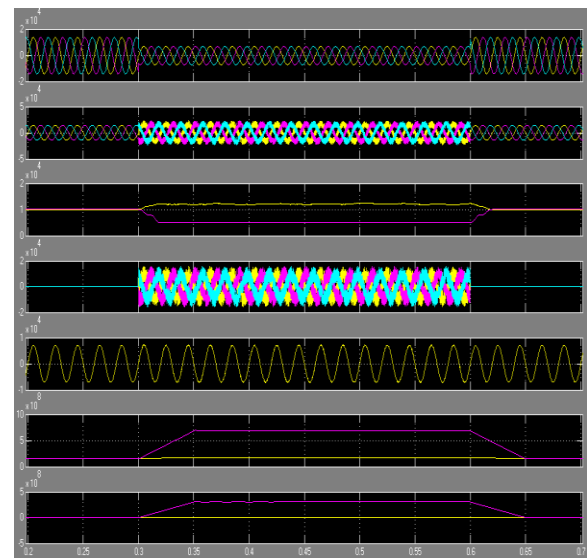

Fig. 4 Simulation results- Mitigation of voltage sag (impulsive) Using IUPQC

- (a) Instantaneous source voltage (kV)
- (b) Instantaneous load voltage (kV)
- (c) Three phase load and source r.m.s voltage
- (d) Voltage injected by UPQC (kV)
- (e) Load current (KA)
- (f) Source and load active powers (MW)
- (g) Source and load reactive powers (MVAR).

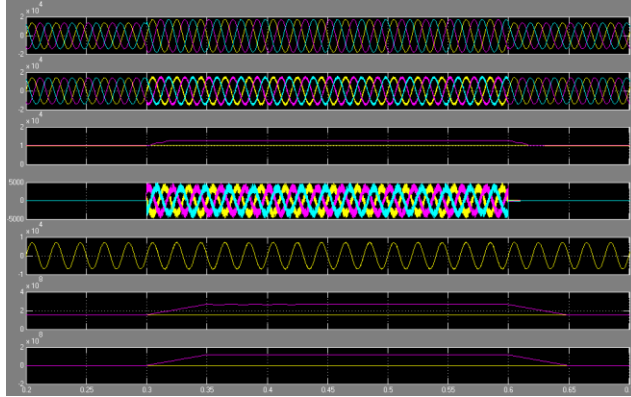

Fig.5. Simulation results- Mitigation of a voltage swell (momentary)

- (a) Instantaneous source voltage (kV)
- (b) Instantaneous load voltage (kV)
- (c) 3- Φ load and source r.m.s voltage (pu)
- (d) Voltage injected by UPQC (kV)
- (e) Load current (kA)
- (f) Source and load active powers (MW)
- (g) Source and load reactive powers (MVAR)

V. CONCLUSIONS

The Sinusoidal Pulse Width Modulation based control scheme for the proposed IUPQC has been described. The control scheme for IUPQC with shunt (PI) controller and series voltage controller has been developed.

- (a) Instantaneous source voltage (kV)
- (b) Instantaneous load voltage (kV)
- (c) 3- Φ load and source r.m.s voltage (pu)
- (d) Voltage injected by UPQC (kV)
- (e) Load current (kA)
- (f) Source and load active powers (MW)
- (g) Source and load reactive powers (MVAR)
- (h) Harmonic analysis at load during fault (%)

The IUPQC can mitigate various power quality disturbances like sag, swell, momentary interruption, over voltages, under voltages, harmonics, noise, etc. The IUPQC discussed in this project is capable of

handling system in which the loads are unbalanced and distorted.

It has been observed that an IUPQC is able to protect the distribution system from various disturbances occurring either in Feeder-1 or in Feeder-2. As far as the common dc link voltage V_{dc} is at the reasonable level, the device works satisfactorily. The angle controller ensures that the real power is drawn from Feeder-1 to hold the dc link voltage constant. Therefore, even for voltage sag or a fault in Feeder-2, VSC-1 passes real power through the dc capacitor onto VSC-2 to regulate the load voltage.

The simulated results shows that PI controller of the shunt filter (current control mode), series filter (voltage control mode) compensates of all types of interruptions in the load current and source voltage, so as to maintain sinusoidal voltage and current at load side. The series filter was tested with different types of interruptions. The simulated results show that in all the stages of circuit operation, the feeder-2 load voltages and load currents are restored close to ideal supply.

For all the types of disturbances (interruptions) the Total Harmonic Distortion (THD) after compensation is to be less than 5% which is as per IEEE standards.

REFERENCES:

- [1] A. Ghosh and G. Ledwich, Power Quality Enhancement Using Custom Power Devices. Norwell, MA: Kluwer, 2002.
- [2] F. Z. Peng and J. S. Lai, "Generalized instantaneous reactive power theory for three-phase power systems," IEEE Trans. Instrum. Meas., vol. 45, no. 1, pp. 293–297, Feb. 1996.
- [3] G. Ledwich and A. Ghosh, "A flexible DSTATCOM operating in voltage and current control mode," Proc. Inst. Elect. Eng., Gen., Transm. Distrib., vol. 149, no. 2, pp. 215–224, 2002.
- [4] M. K. Mishra, A. Ghosh, and A. Joshi, "Operation of a DSTATCOM in voltage control mode," IEEE Trans. Power Del., vol. 18, no. 1, pp.258–264, Jan. 2003.
- [5] A. Ghosh, A. K. Jindal, and A. Joshi, "A unified power quality conditioner for voltage regulation of critical load bus," in Proc. IEEE Power Eng. Soc. General Meeting, Denver, CO, Jun. 6–10, 2004.
- [6] A. Ghosh and G. Ledwich, "A unified power quality conditioner (UPQC) for simultaneous voltage and current compensation," Elect Power Syst. Res., vol. 59, no. 1, pp. 55–63, 2001.